



# **Trends in Modern Business Process Simulation Tools**



**Kit Jones**  
**Christine McCarty**  
**SEPG North America**

March 2009

# Outline

- **Introduction**
- **Simulation Analysis for Ongoing Process Improvement**
- **Process Analysis and Simulation**
- **Sophistication Level 1 Case Study – Nurse Recruitment**
- **Sophistication Level 2 Case Study – Enlisted School Planning**
- **Sophistication Level 3 Case Study – Census Management**
- **Summary & Questions**
- **Contact Information**

Download slides at [www.simprocess.com](http://www.simprocess.com)



- **Business Process Simulation tools are evolving to become well-integrated components of Business Process tool sets**
  - The simulation engine is often imbedded in a business process tool with a broader scope and capabilities
  - Modeling information and performance data are freely exchanged between the simulation component and the other components
- **This tutorial will explore and demonstrate these concepts**



# Why Simulate?

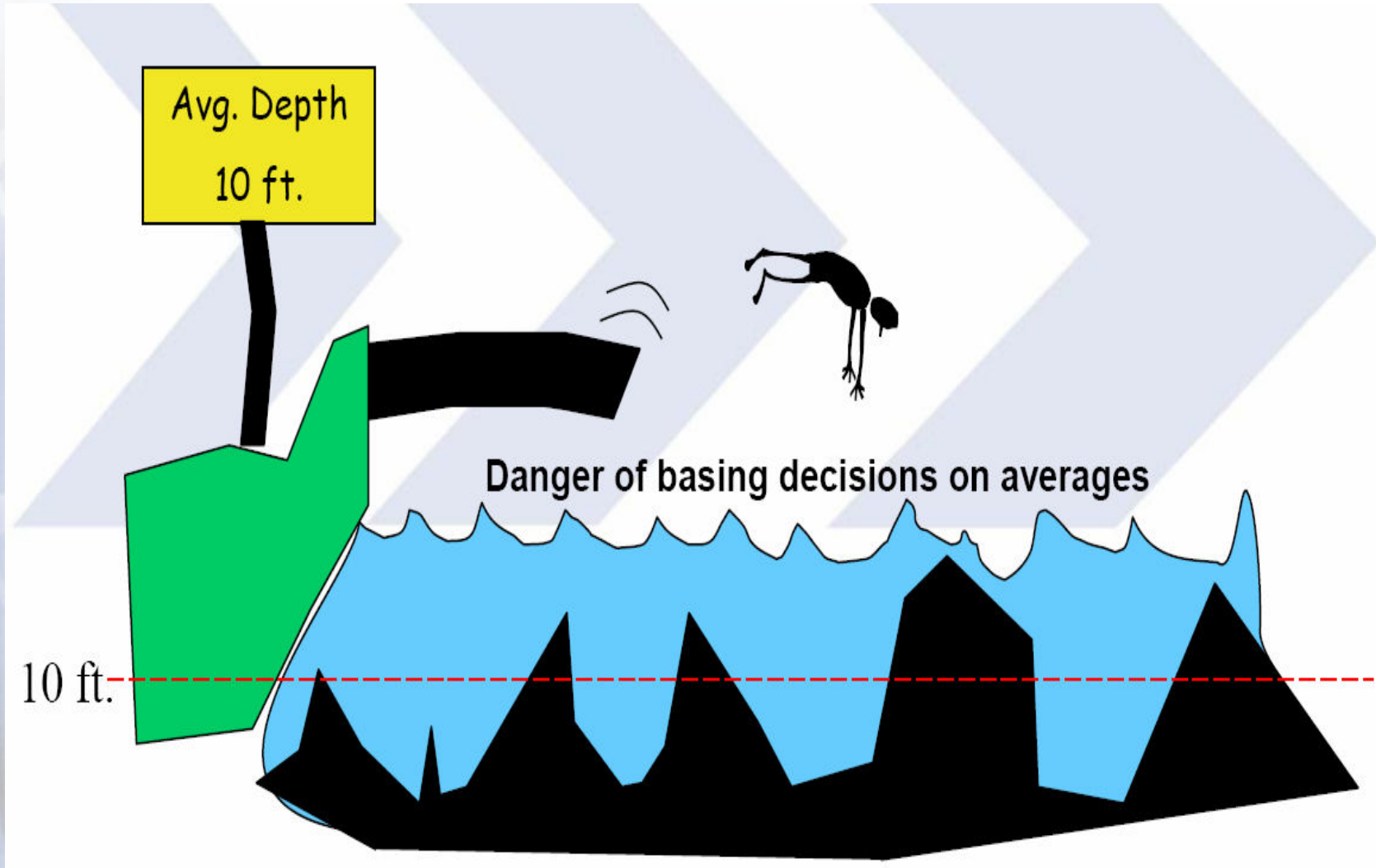

# Using Simulation for Analysis

- The power of simulation can be made available for operations managers to add a predictive capability to their business process monitoring without adding to their workload.
  - The difficulty of performing useful analysis using static techniques will be discussed and then compared to the same analysis using simulation modeling.
  - Optimizations of complex processes (e.g., Lean/6-Sigma) are beyond the capability of static modeling tools (e.g., spreadsheets) and require tools such as simulation to facilitate accounting for non-linear interdependencies.
  - Improvements in analysis results that are enabled by incorporation of live data and probability distributions will be demonstrated and explored.
  - Optimization engines expedite determination of maximum efficiencies and the associated resource levels.
- Case studies for each Sophistication Level will demonstrate resource sharing among several independent and significantly different tasks.
  - Examples will show levels of simulation model sophistication with discussion of their relative capabilities and the appropriate application for each Level.



# ***Simulation Analysis in Ongoing Process Improvement Programs***

- **Simulation analysis can be incorporated into a continuous process improvement program.**
  - Sophistication Level 1 for preliminary analyses
  - Sophistication Level 2 for use by line managers
  - Sophistication Level 3 for use by executives
- **Other requirements must be met to support continuous process improvement, such as configuration management and model maintenance.**
  - Use change management processes identical to those used for software development.
- **Policies should be in place to address simulation modeling issues that arise due to model maintenance and updating.**





# Meeting Service Level Agreements

- **Techniques will be shown which ensure processes meet Service Level Agreements (SLAs) while maximizing efficiency.**
  - Current analysis techniques required significant margins in staffing levels (thereby introducing higher costs) to ensure SLAs are met.
  - This is because interdependencies between widely separated activities are very difficult to model using static analysis techniques; this forces the analyst to rely on wider estimation margins to ensure SLA objectives will be met.
  - Discrete-event simulation models are object-oriented and therefore only require the modeler to specify an activity's input/output behavior and the associated resource requirements.
- **During the simulation, resource utilization and contention is managed and reported by the simulation engine.**
  - This permits significantly more complex process models than static analysis and significantly improved estimates of optimal resource allocations that will ensure meeting an SLA.
  - Also demonstrated will be the ability of discrete-event simulations to produce probability distributions and how this data is used to examine the dependencies between SLA confidence level objectives and resource levels.



# CMMI-SVC and Simulation

- **Service Delivery (SD). Modeling can aid in establishing realistic service agreements and in identification of customer satisfaction data**
- **Service System Transition (SST). Modeling can aid in analysis of service system transition needs and in planning for transition**
- **Incident Resolution and Prevention (IRP). Modeling may help to identify and develop workarounds to enable services to continue despite incidents**
- **Capacity and Availability Management (CAM). Modeling can help to determine if resources are available in sufficient quantity, and provide higher confidence in estimates of future capacity and availability**
- **Service System Development (SSD). Modeling can help identify alternative approaches for delivery, ensure service requirements are met, and aid in analyzing and validating requirements**





# Why Use Simulation to Solve a Problem?

## 1. Static modeling

- **Pro:** fast, doesn't require much input, formula-based results.
- **Con:** unreasonable assumptions.

## 2. Simulation

- **Pro:** *dynamic* view of system, handles complex interactions. Can reduce risk/cost of prototype/pilot.
- **Con:** requires many inputs, may be difficult to verify and validate

## 3. Prototype/Pilot (*i.e. test & measurement*)

- **Pro:** real-life trial/analysis of proposed solution
- **Con:** costly and *time consuming*.



# Simulations Provide Insight on Behavior

Average Data of 1 Replication for 5 Months

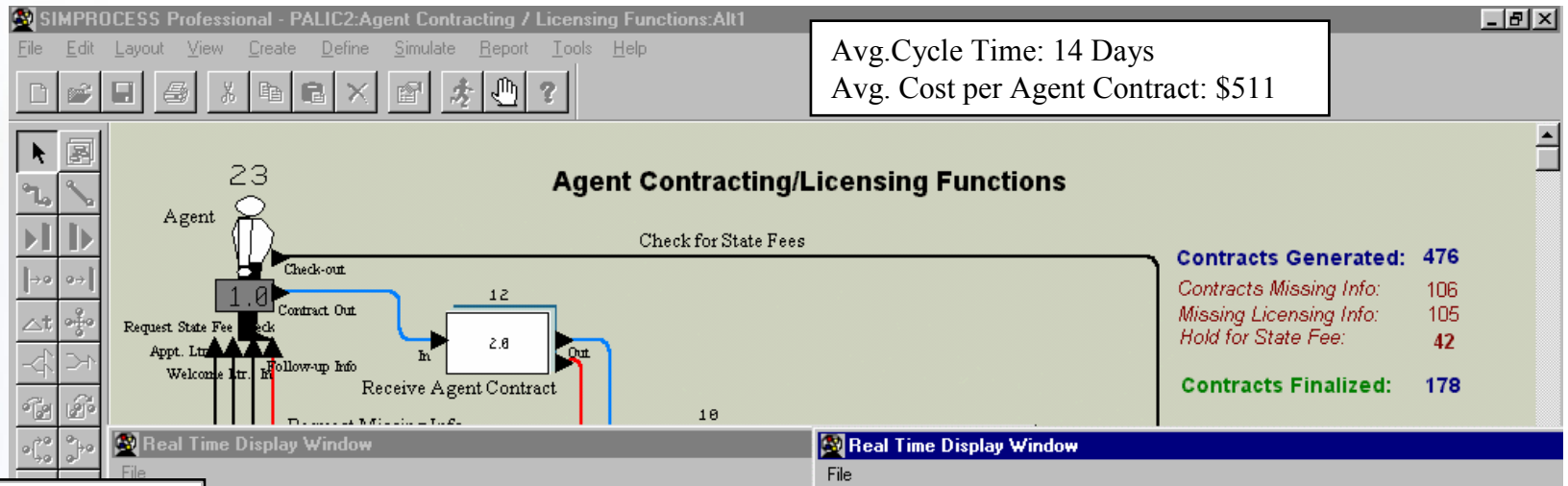

Resource : Cost Of Use

Resource Name	Total Cost
Licensing Clerk	\$ 21,354.85
Manager	\$ 25,186.14
Lead Clerk	\$ 42,648.60
Data Entry Clerk	\$ 18,036.25
Contracting Clerk	\$ 24,251.44
	<b>\$ 131,477.28</b>

Resource : Percent Utilization By State

Resource Names	Percent Utilization	
	Idle	Busy
Licensing Clerk	21.00%	79.00%
Manager	63.00%	37.00%
Lead Clerk	7.00%	93.00%
Data Entry Clerk	20.00%	80.00%
Contracting Clerk	40.00%	60.00%

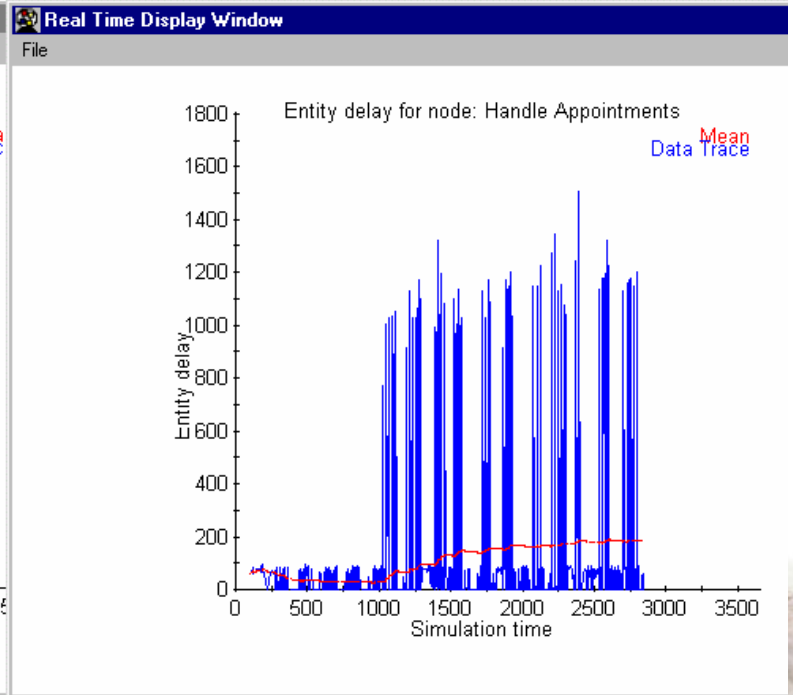
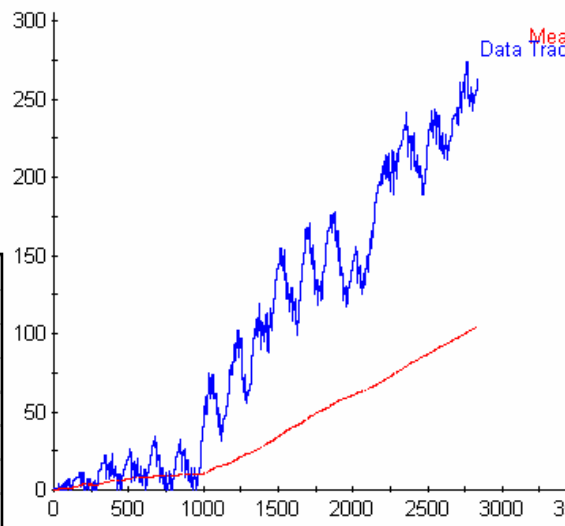

# Simulation Overview

- Process simulation is the technique that allows the **representation of processes, people, and technology** in a ***dynamic*** computer model.
- The simulation **mimics the operations** of the business by stepping through events in ***compressed time*** while displaying an animated picture of the workflow.
- Simulation software **keeps track of all statistics** about model elements which can then be evaluated by analyzing the ***model output data***.
- The **resources required to satisfy agreements** with customers addressed by ***CMMI for Services*** can be simulated to demonstrate how changing resources will affect delivery



# Process Analysis and Simulation



Build Model, Simulate, and Obtain Results

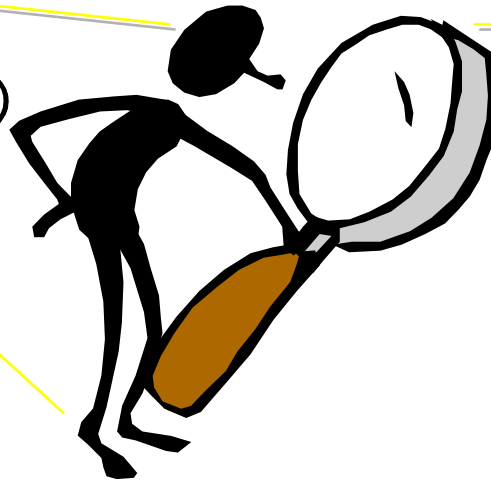

Analyze Results

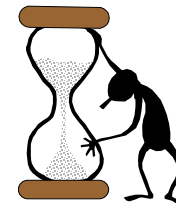

Cycle Time



Capacity

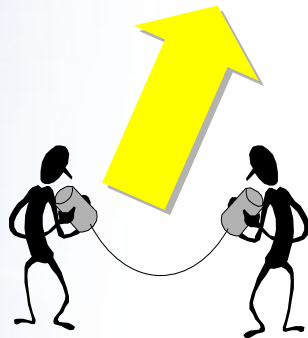

Collect Modeling Information from Subject-Matter-Experts



Bottlenecks



Activity Based Costing



# Process Analysis & Simulation used to develop and evaluate business alternatives

How many sorters to process 11 million forms/day?

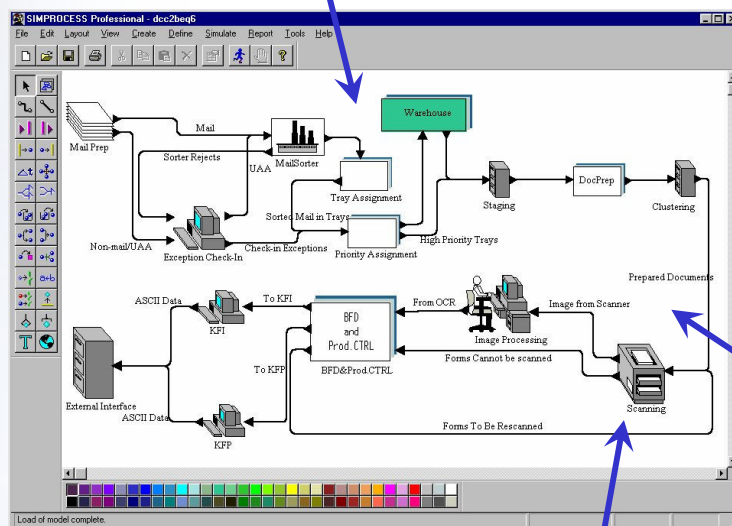

- Capacity of system elements
- Equipment and human resources required for each process
- Cost of adequate resources
- Balancing of network flow

Will our network handle the data flows?

How many scanners do we need to process 160 million forms in 100 days?



# Simulation Analysis in Lean/6-Sigma

- **Simulation analysis has a natural role in Lean/6-Sigma analysis and in continuous Process Improvement.**
- **When is it appropriate to use simulation to assess process performance in a Lean/6-Sigma environment?**
  - No advantage for uncomplicated and easily predicted processes
  - Should always be used when process behavior is a factor (e.g., process dynamics).
- **Data collection requirements and techniques are very similar to those for other analysis techniques except minimum, maximum and typical (mode) values should be collected.**
  - Use averages for metrics that are unbounded





# Process Analysis & Simulation offers important benefits

*With Process Analysis & Simulation, we can . . .*

- **Measure**
  - Time, Cost, Resources, Throughput, Capacity, Bottlenecks
- **Visualize/Validate**
  - Current Process, Problems, System States, Organization Relationships
- **Design/Test Improvements**
  - Resource Allocation, Streamlining, Leverage Technology
- **Develop Business Case**
  - Performance Data, Financial Data, Return on Investment
- **Communicate**
  - Process Owners, Decision Makers, Implementation Team



# Results and Benefits - Examine Alternatives

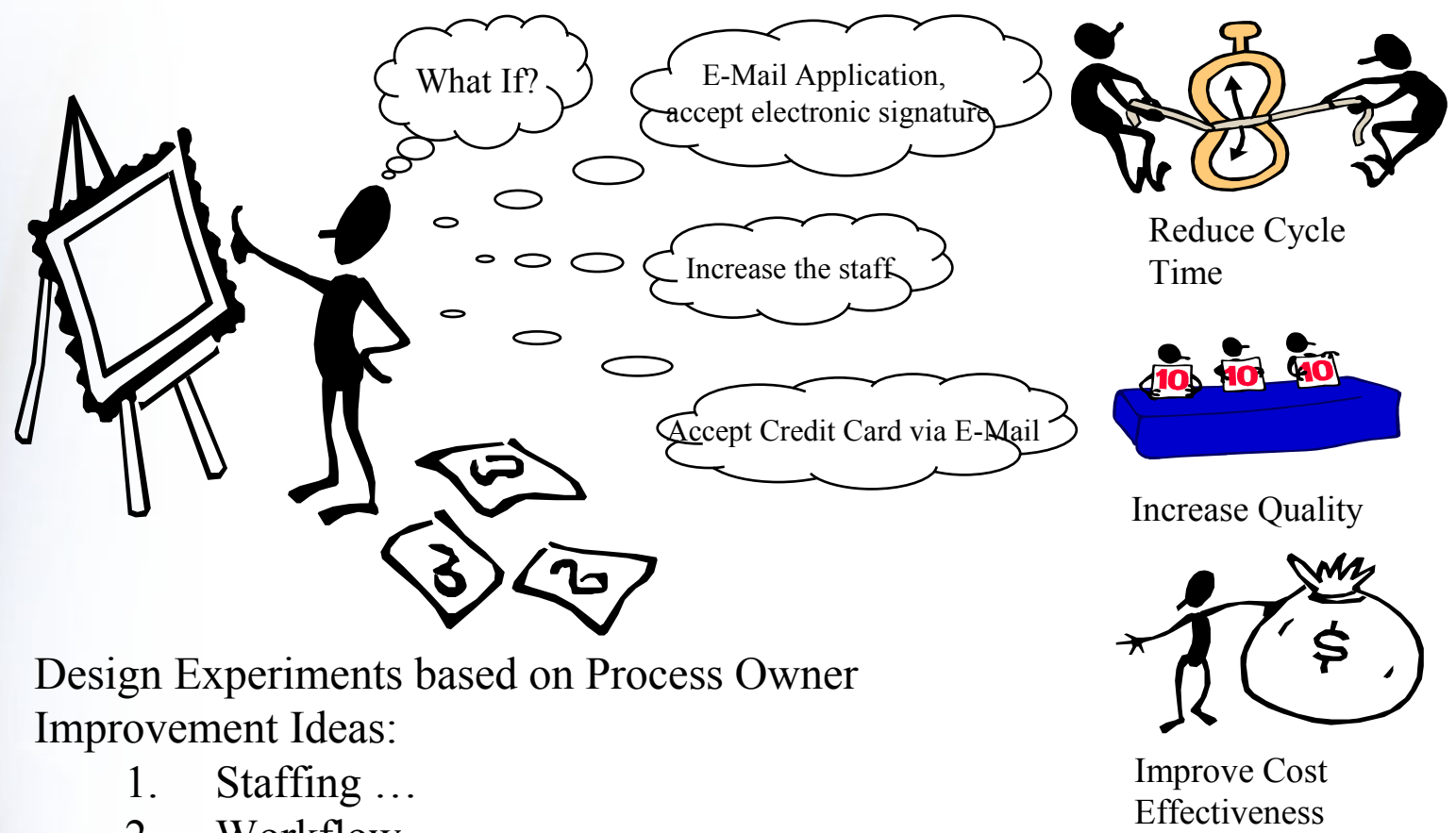

Design Experiments based on Process Owner

Improvement Ideas:

1. Staffing ...
2. Workflow ...
3. Systems ...
4. Business Rules ...



# Evolution of BP Simulation

- **Business process simulation tools are evolving through 3 Levels of Sophistication that culminate in permitting decision makers to independently (without the modeler's assistance) specify and answer analysis questions based on live data.**
  - Providing technical concepts on how to deliver predictive analytics as a service in an SOA such as the GCSS-AF Integration Framework
  - Providing an understanding of how Business Intelligence Dashboards can benefit from predictive analytics



# As the Model Matures Complexity for the User Decreases

## Sophistication Level 1

Desktop simulation models used by simulation modelers to support operational improvement analysis.

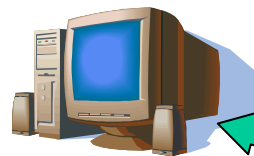

## Sophistication Level 2

Web-server hosted operational analysis tools available to a large community of functional analysts and decision makers.

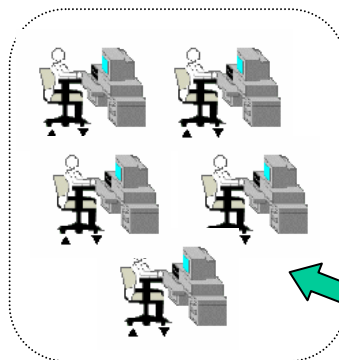

## Sophistication Level 3

Automated Predictive Analytics for proactive operations management by line managers and administrators.



*(triggered by live data and events)*

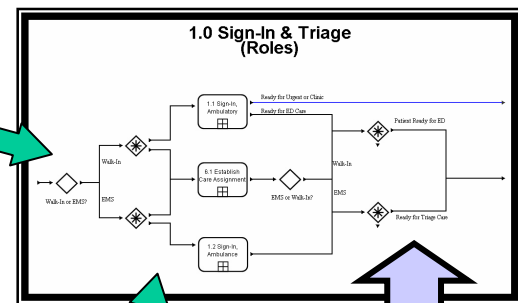

Data from Business Activity Monitoring  
*(historical & real-time)*

HIGH



LOW

LOW

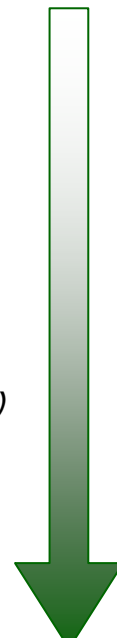

HIGH

Complexity  
of Solution

Training Required  
User Involvement  
w/ Model Details

# ***Sophistication Level 1 Case Study – Nurse Recruitment***

- **Design, implement, and measure pilot recruiting program**
  - Candidate Sourcing and Recruitment Marketing
  - Nurse Recruitment and Selection Process
- **Address the following components**
  - Employer branding
  - Interactive advertising
  - Internet technologies
  - Automated staffing systems
  - Hiring process
- **Report findings and offer recommendations**



# Nurse Recruitment Process Reengineering

- **New hires**
  - Can reduce average time-to-fill from **72 days to 25 days**
  - 95 percent can be filled in **31 days instead of 92**
- **Employee transfers**
  - Can reduce average time-to-fill from **33 days to 13 days**
  - 95 percent can be filled in **17 days instead of 40**
- **Recommendations address approval authority, paid advertising, streamlined processes, electronic documents, lead time for physicals, and document tracking.**





# Compiling Document Tracking Information

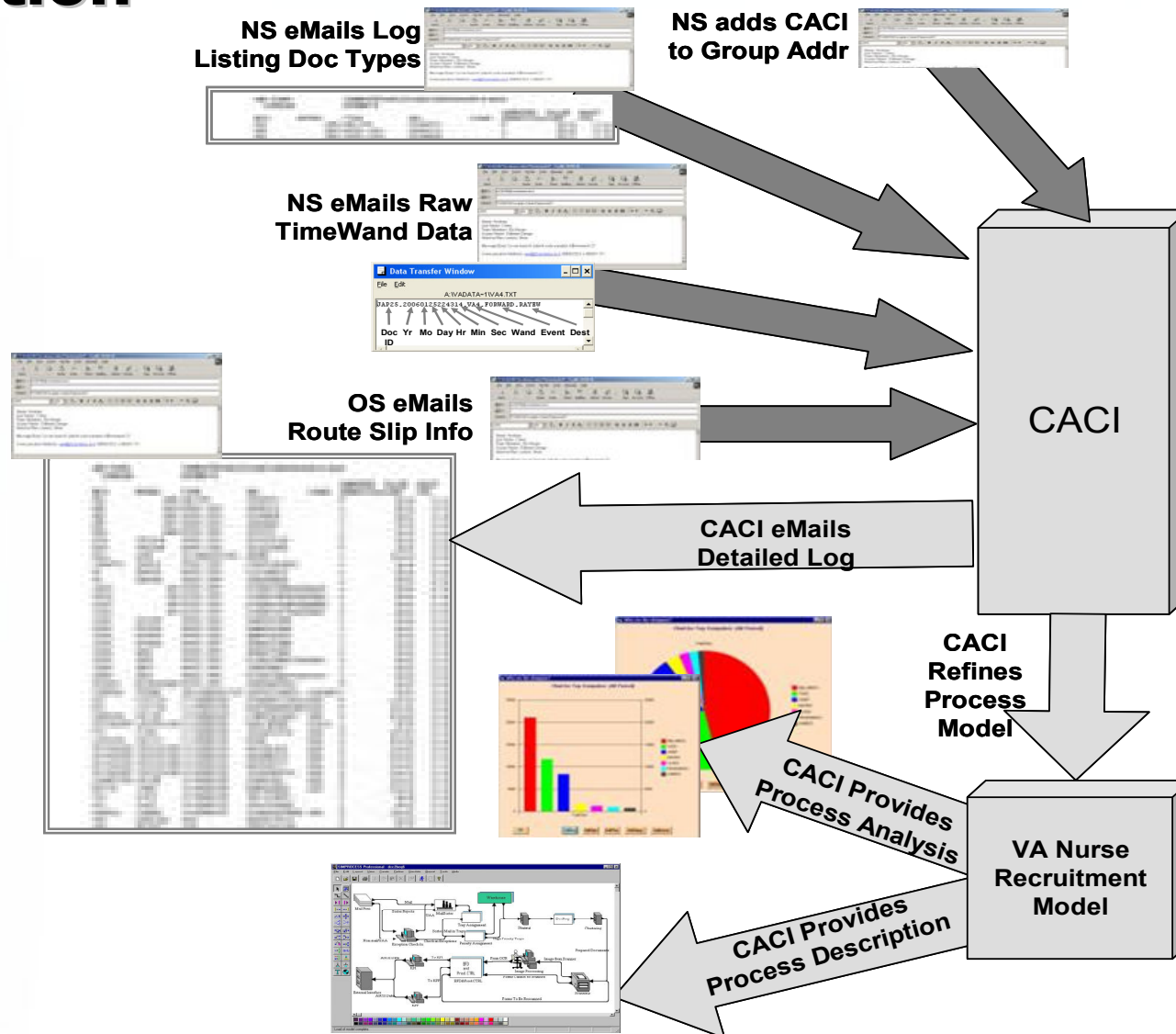

# Process Described Using Drill-down Approach

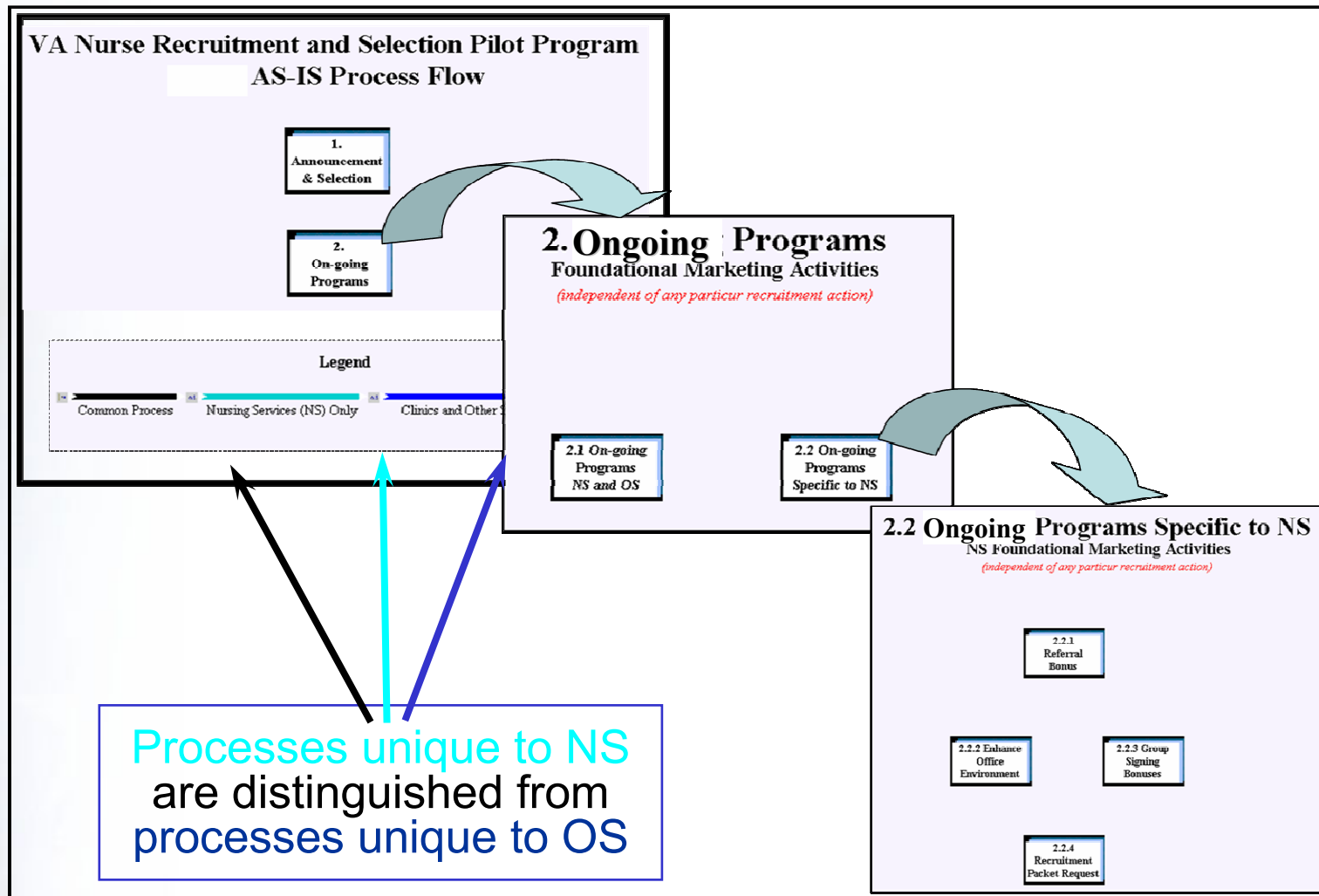

# Process Described Using Drill-down Approach

SIMPROCESS Model of Nurse Recruitment & Selection Process:

- 144 Individual Tasks
- 79 Logical Branches

## Top-level View of Process:

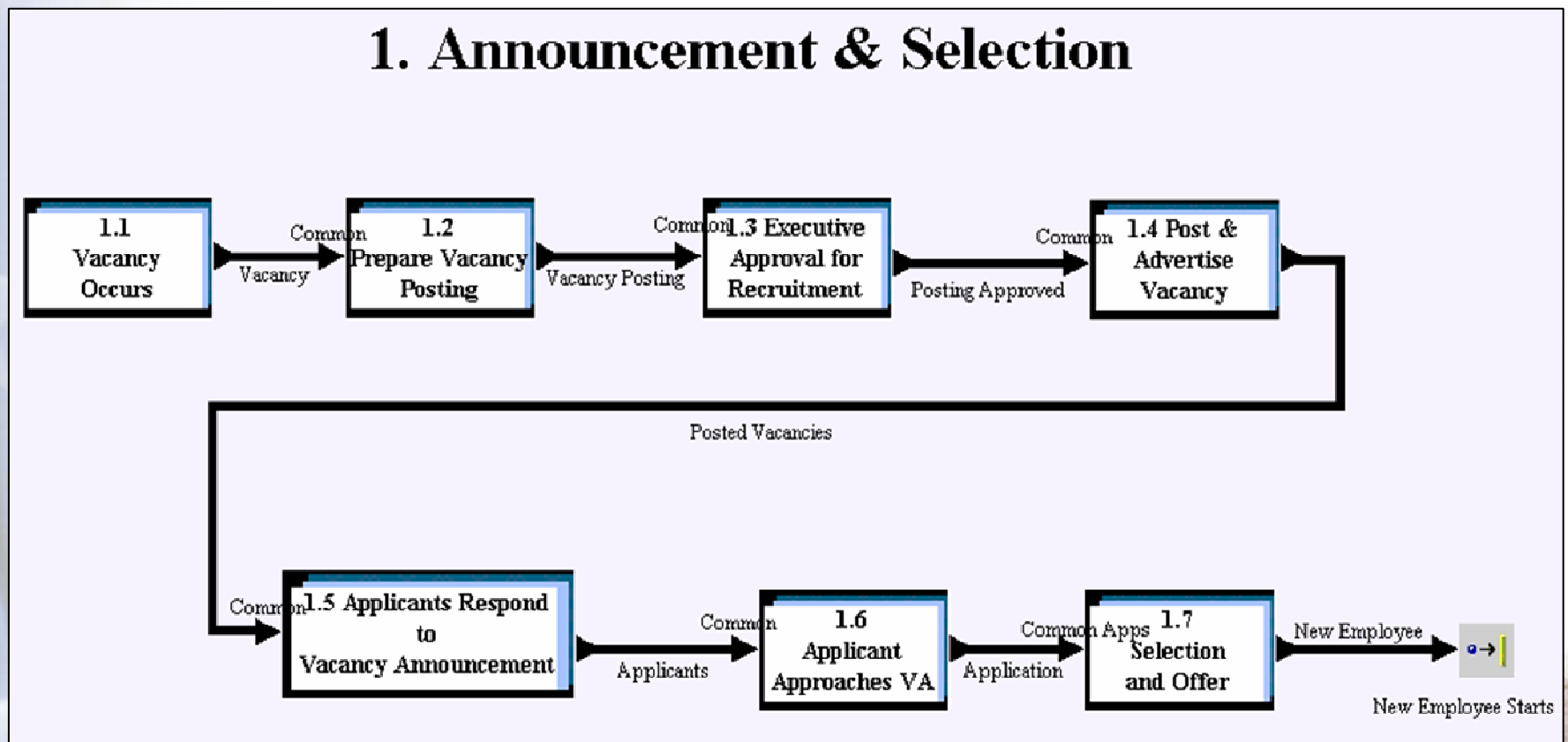

# Process Recommendations

1. **Delegate approval authority** for decisions such as recruitment, paid advertising, bonuses and selection to lowest possible level in the organization.
2. **Make greater use of paid advertising** – A comprehensive approach complete with implementation detail is addressed in the Marketing portion of this report.
3. **Standardize on Streamlined Processes** – Establish a minimum duration for the time required to announce a position that reflects ubiquitous web access
  - Provide for parallel vacancy announcements within VA and on the Web
  - Provide fingerprint results in 48 hours
  - Provide for drug test analysis in parallel with time frame to receive results from the physical exam
  - Eliminate the requirement to schedule EOD for the start of the next pay period
  - Eliminate the wait time for an orientation session by using techniques such as Web-based meetings
4. **Electronic Documents**
  - Eliminate delays in receiving applications mailed to VA.
  - Eliminate the internal interoffice mailing delays.
  - Provide automatic compilation of document processing status that is up-to-the-minute and accurate.
  - Automate availability of recruitment status.
  - Automate compilation of recruitment document processing metrics.
  - Minimize the information burden on the applicant by linking the information submitted.
5. **Streamline VetPro** – These measures consist of database techniques and process improvement:
  - Use database tools to take advantage of all information the nurse applicant has submitted previously.
  - Employ applicant as a conditional hire where VetPro can be completed within 60 days of EOD.
6. **Reduce Lead Time for Physical** – The current average 21-day lead time could be cut in half by the increasing the resources and optimizing scheduling process.
7. **Document Tracking** – In any subsequent BPR effort where the progress of applications is not readily available in existing databases, employ a Radio Frequency ID System (RFID) accuracy of the information obtained.



# Vacancies Filled During 4-yr Simulation of AS-IS

## SIMPROCESS Model of Nurse Recruitment & Selection Process:

- 900 Vacancies posted (*average of 18 per month for NS & OS*)
- 2,438 Applications processed (*average of 2.6 per announcement*)

## Pattern of Days-to-Fill:

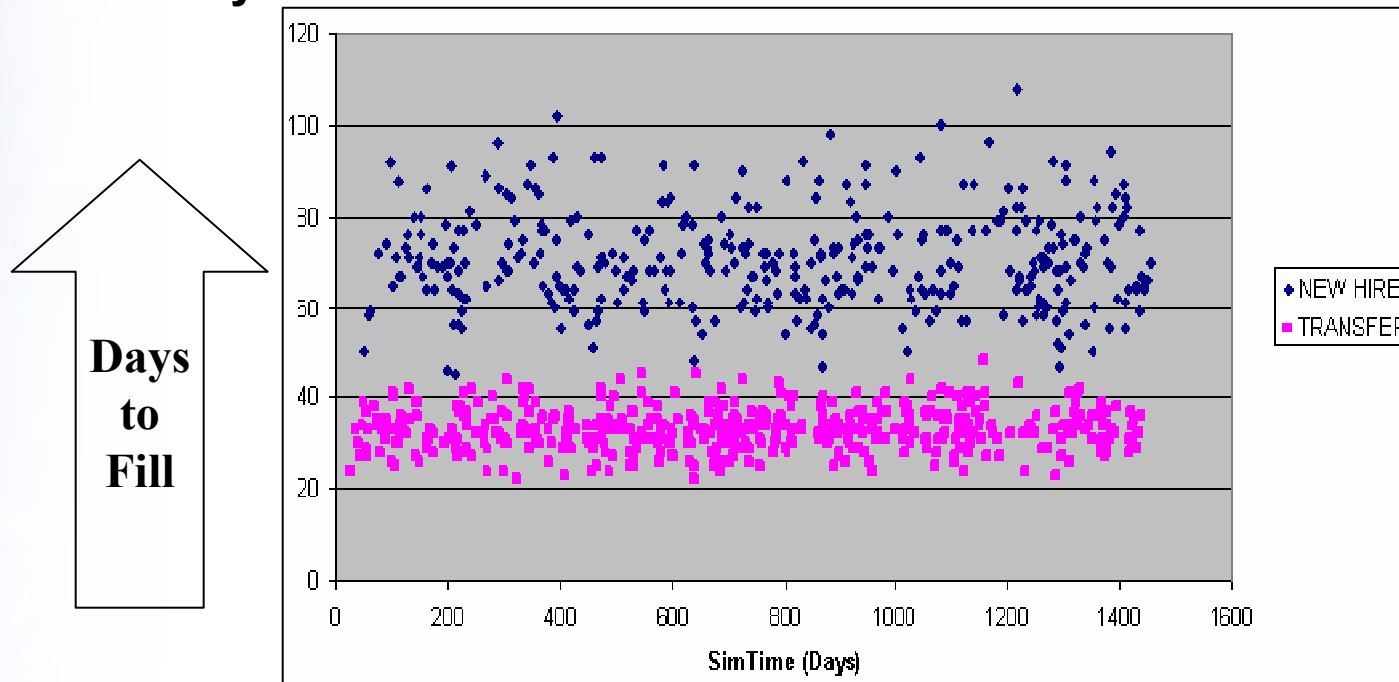

# Vacancies Filled During 4-yr WHAT-IF Simulation

## SIMPROCESS WHAT-IF Model of VA Nurse Recruitment & Selection Process:

- 900 Vacancies posted (*average of 18 per month for NS & OS*)
- 3,931 Applications processed (*average of 4.4 per announcement*)  
(*vs. 2.6 for AS-IS*)

## Pattern of Days-to-Fill:

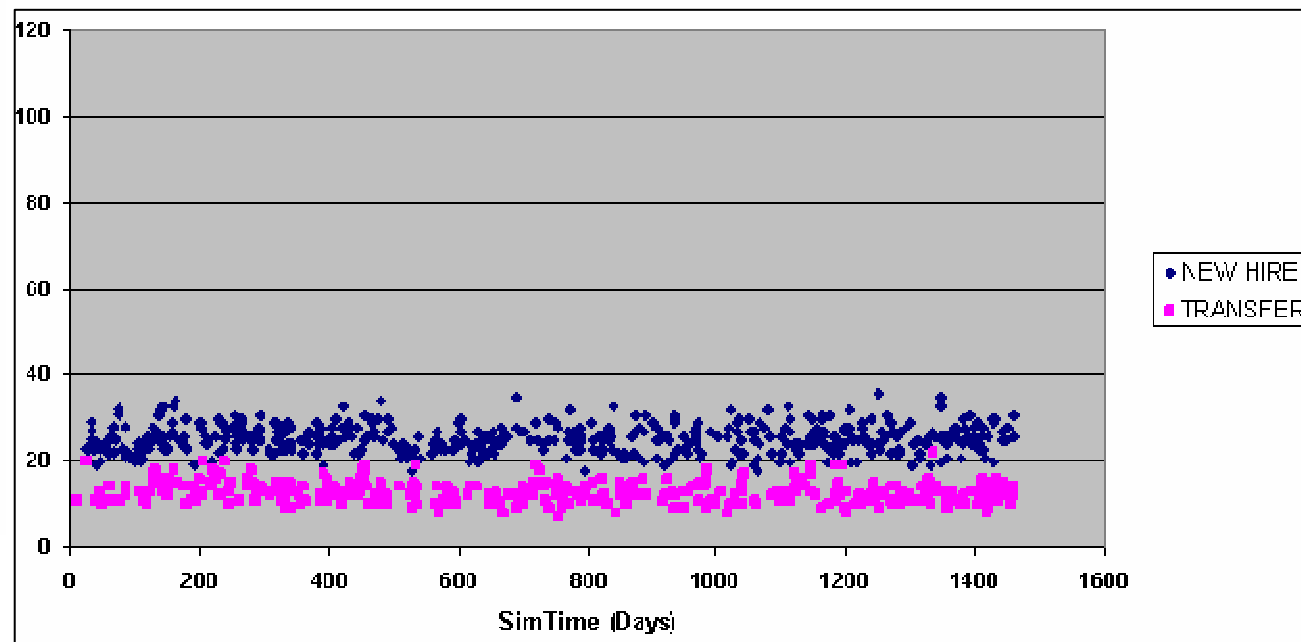



# AS-IS Probability Distribution of Vacancies Filled

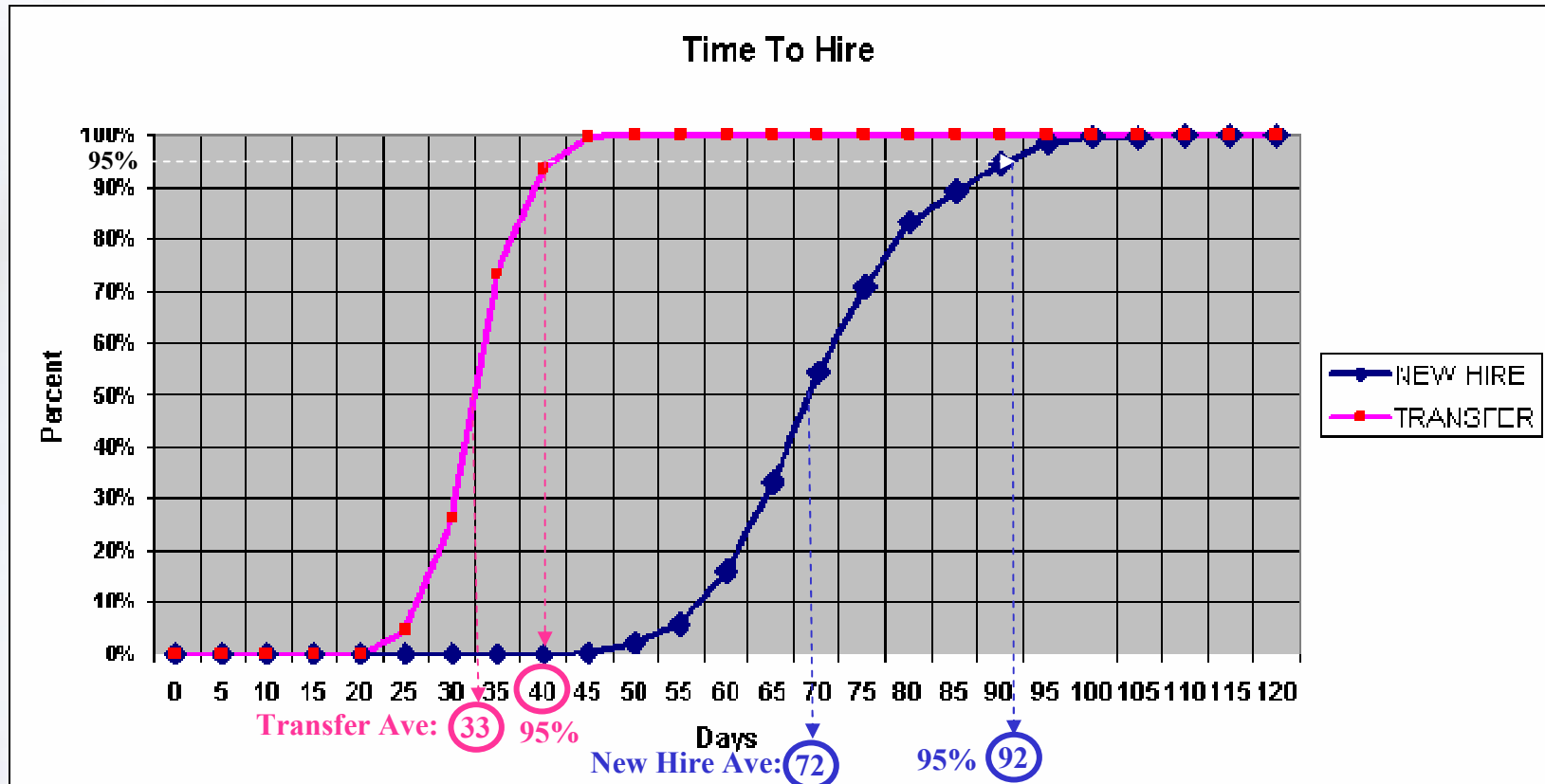

# WHAT-IF Probability Distribution of Vacancies

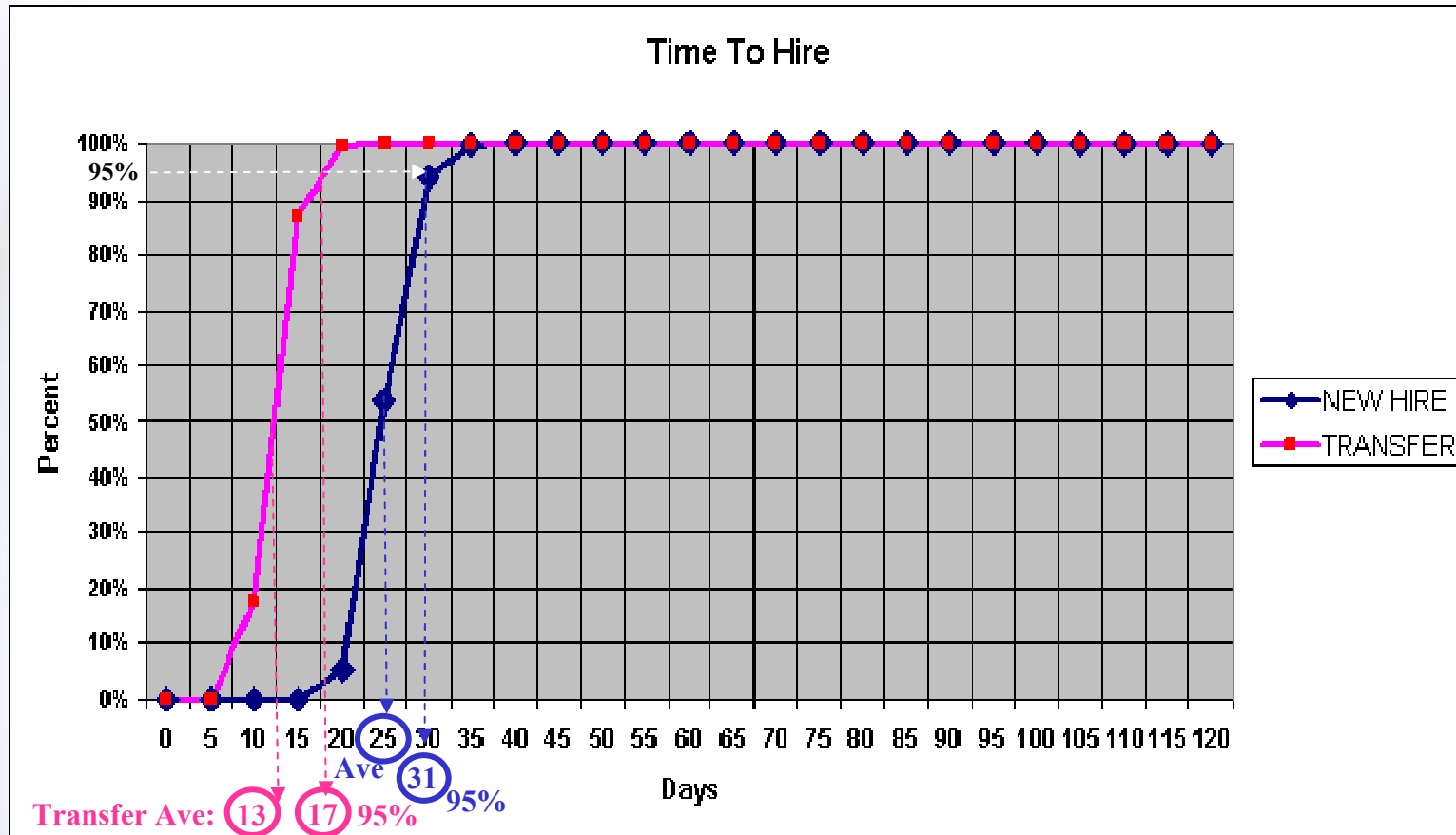

# ***Sophistication Level 2 Case Study – Enlisted School Planning***

- Developed integrated performance models for management to make well informed and well educated decisions for their programs.
  - **The performance models address managing resource requirements, resource projections and/or associated budget projections.**
  - **The models are also used to conduct “what-if” studies to support trade-off analyses.**
- A web-based application was created that wrapped around the simulation models to provide a robust decision support system for the Navy.



# Interoperability Between Business Process Management and BPA

- Because Business Process Analysis (BPA) is always within the context of a larger effort, there is a clear value for such analysis tools to be interoperable and/or integrated with other business process management and monitoring applications.
- Modern process simulation tools are now starting to exhibit this capability.
- They now support being integrated (and/or imbedded) with Business Intelligence, Business Process Management/Monitoring and other similar tools to facilitate Lean/6-Sigma analysis and continuous process improvement to utilize real-time data.
- Interoperability is made possible by providing import/export and data exchange features that conform to published standards such as BPEL, XPDL & SOAP, OLAP and the use of client/server networking architectures.



# Sophistication Level 2 Architecture

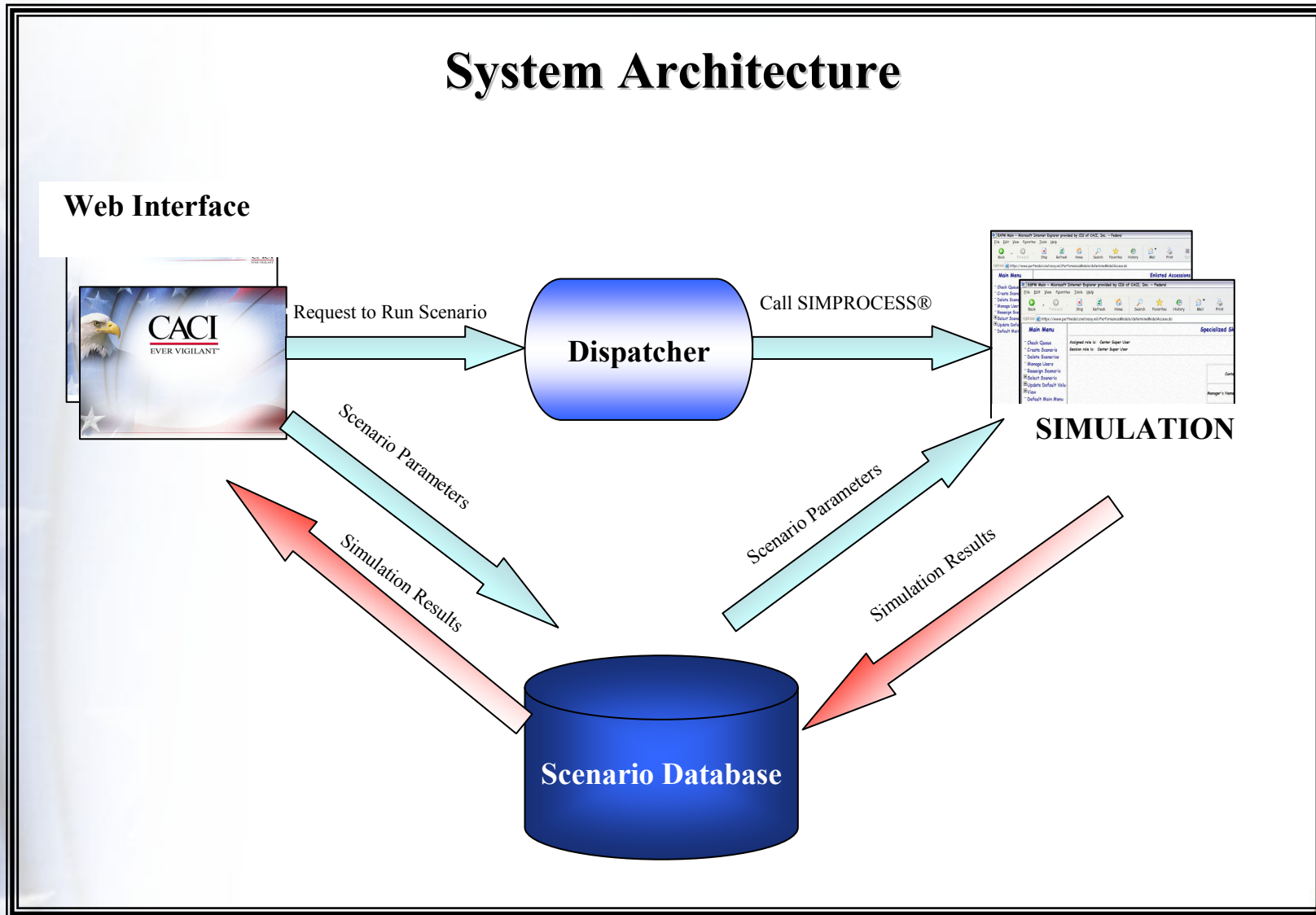

# Simulation on Demand - Sample Architecture

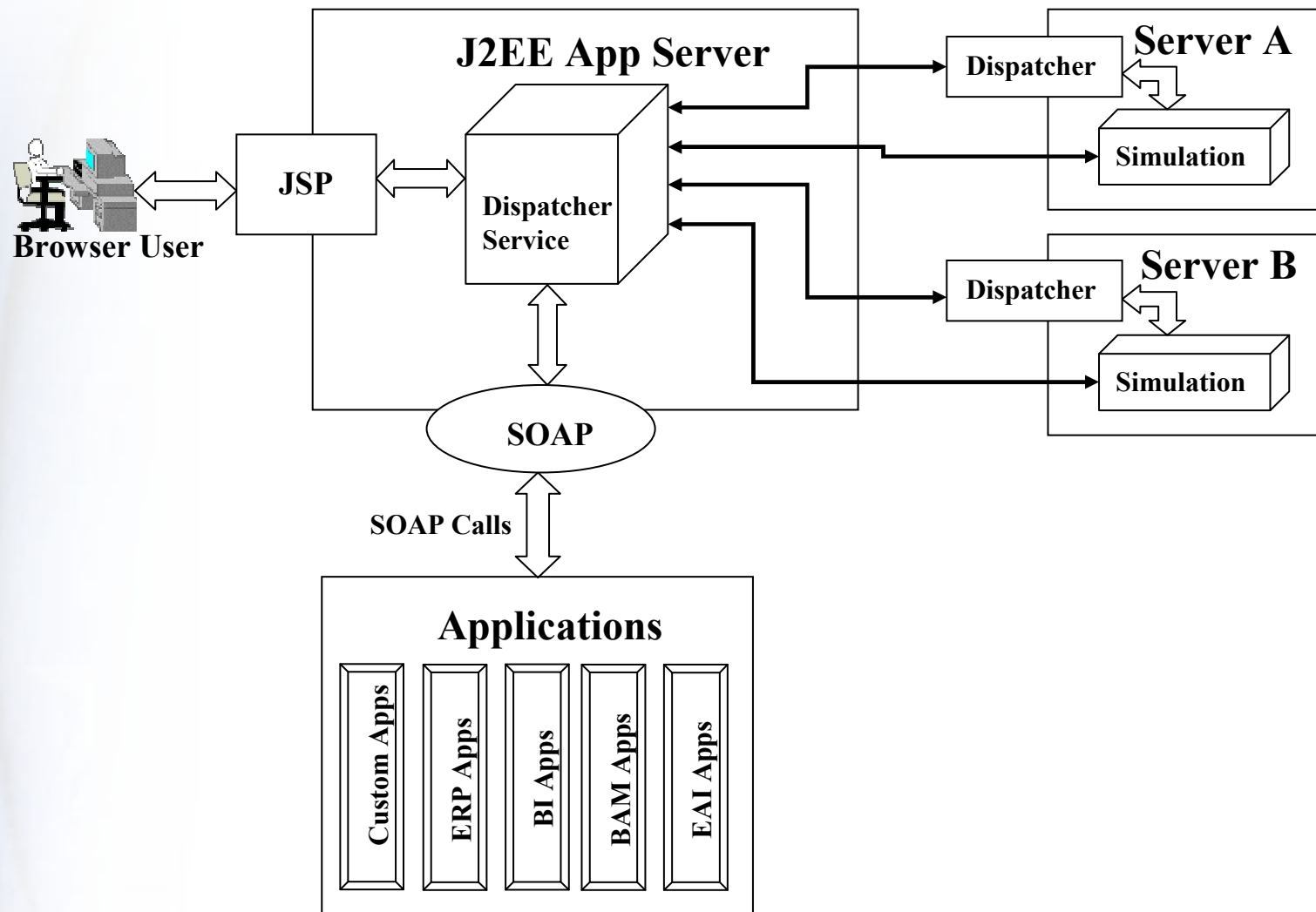



# Enlisted Accession Performance Model (EAPM)

- The EAPM is used to help better manage the resources required for training and the ability to adjust training schedules to meet the projected recruiting and training needs.
- The performance model uses the actual training schedules to extract major processes and resource requirements for the model. The simulation runs with the schedule information plus other scenario parameters to produce usable results.
  - **Sample Results:**
  - **Number of recruits accepted per year**
  - **Number of recruits completed training per year**
  - **Student costs (e.g., food, housing, etc.)**
  - **Instructor costs**
  - **Staff costs**
  - **Attrition rates**





## Main Menu

- Check Queue
- Create Scenario
- Delete Scenarios
- Manage Users
- Reassign Scenario
- + Select Scenario
- + Default Parameters
- + Views
- Default Main Menu

## Specialized Skills Performance Model

Assigned role is: Main Super User

Session role is: Center Super User

Currently Logged into Center #16 - CENSUBLEARNING

### Contact Model Manager

Manager's Name	Email Address
Luis Suarez	<a href="mailto:luis.o.suarez@navy.mil">luis.o.suarez@navy.mil</a>
Katie Petrillo	<a href="mailto:katie.petrillo@navy.mil">katie.petrillo@navy.mil</a>
Cliff Pish	<a href="mailto:clifford.pish@navy.mil">clifford.pish@navy.mil</a>

Select an option from the menu to enter a Scenario name and to the Scenario Manager

From the Main Menu ...

### Basic Users can:

- Check the status of running scenarios
- Create a new scenario
- View all authorized scenarios
- Select a previously saved scenario
- View default parameter values

### Super Users can:

- Reassign scenarios between users
- Manage user permissions
- Delete obsolete scenarios
- Update the values associated with default parameters
- View all scenarios





Currently Logged into Center #16 - CENSUBLEARNING

CP: 5878

The Master Course Schedule provides the basis of student simulation.

Sequence Number	Event Type	Number of Periods	Topic Title	Student Quantity	Instructor Quantity
1	CLASSROOM	1	INDOCTRINATION	12	1
2	CLASSROOM	3	K AND C OF BASIC HANDTOOLS AND MECHANICAL FASTENE	12	1
3	CLASSROOM	2	K & C OF TORQUE WRENCHES	12	1
4	LABORATORY	6	K, C & A OF LOCK WIRING	12	1
5	PERFORMANCE TEST	1	K, C & A OF LOCK WIRING	12	1
6	CLASSROOM	1	K & C OF MECHANICAL SAFETY	12	1
7	CLASSROOM	2	K & C OF VALVES	12	1
8	CLASSROOM	2	K & C OF FLUIDS AT REST (HYDROSTATICS)	12	1
9	CLASSROOM	2	K & C OF FLUIDS IN MOTION (HYDRAULICS)	12	1
10	CLASSROOM	6	K & C OF RADIATION	12	1
11	CLASSROOM	1	WITHIN COURSE COMPREHENSIVE REVIEW	12	1
12	CLASSROOM	2	WITHIN COURSE COMPREHENSIVE TEST #1 (WRITTEN)	12	1
13	CLASSROOM	3	WITHIN COURSE COMPREHENSIVE TEST #1 REVIEW	12	1

- Grads and Setbacks
  - Hold Durations
  - Student Input Plan
  - Update CDP
  - Master Course Schedule
    - CDP[s] No MCS
    - Update MCS
- Views
  - All Centers
  - Center Specific
  - Misc Data Views
  - Default Main Menu

Help Save





### Scenario Maintenance Menu

- [-] Maintain Scenario
  - Change Scenario Access Level
  - Copy Scenario
  - Delete Scenario
  - Update Scenario Description
  - Update Selective Access List
- [-] Process Model

### Set Run Parameters

Start Run Successful! Scenario entered into queued status.

Currently logged into: CENSUBLEARNING  
 Scenario Name: SCENARIO-1  
 Scenario Access Level: PRIVATE

Assigned role is: Center Super User  
 Scenario Owner: MAIN.SUPERUSER

What type of report?

What year should be modeled first?

How many years should be modeled?

Reduce course lengths by the following percent:

Reduce Student throughput by the following percent:

Increase course lengths by the following percent:

Increase Student throughput by the following percent:

Which course types should be modeled?

How should the output be sorted?

Help

Run Scenario

Some *on the fly* what-if capabilities [e.g., Increase Student Throughput ... ] are located on the run screen.





**Scenario Maintenance Menu**

- Maintain Scenario
- Process Model
  - Check Queue
  - Check Run Status
  - Export Data
  - Run Scenario
  - Stop Run
  - View Output
- Scenario Parameters
- Views
  - Main Scenario Screen
  - Main Menu

```
Total Number of Active CDPs Used ..... 506 (70.47%)
- Total Active CDPs Available ..... 718
- Total Excluded ..... 212
```

MODEL RESULTS - OVERALL SUMMARY (1 YEAR TOTAL):

```
=====
Total Number of CDPs Used (718 available) ..... 506
Total Number of Classes ..... 12,559
Average Graduates per Class ..... 9.17
Total Students Graduated ..... 115,168
Average Time to Train ..... 8.67
Total Students Setback but Graduated ..... 0
Total Students Non-Graduated ..... 49
Average Training Days before Non-Graduation ... 1.17
Total Students Setback but Non-Graduated ..... 0

Total Instructors Required (ICOMP) ..... 4,663
- Military Instructors Required ..... 1,166
- Civilian Instructors Required ..... 1,166
- Contractor Instructors Required ..... 2,331

Course Curriculum Model Manager Hours ..... 93,106
- Additional Instructors Required for CCMM
  - If Military Instructors used ..... 107
  - If Civilian Instructors used ..... 60
  - If Contractor Instructors used ... 60
- Number CDPs used with CCMM Indicator 201

Total Center NETC O&M,N Cost ..... $68,814,507
Total Center NETC BOS Cost ..... $18,546,884
Total Center NETC MP,N Cost ..... $272,886,401

Students Still Active when Model Finished ..... 929
** Totals by CDP are listed in OVERALL RESULTS
```

FISCAL YEAR 2006 RESULTS:

TOTAL FY 2006 SUMMARY COSTS

```
** O&M,N Costs Adjusted for Annual Inflation by: 4.00%
** BOS Costs Adjusted for Annual Inflation by: 4.00%
```

**Student and instructor statistics**



# Introduction to Dashboards

- **Dashboards provide the following types of valuable management feedback**
  - High-level business measurements based on operational performance
  - Continuous monitoring against organizational performance objectives (I.e. throughput, cost, efficiency, cycle time, etc.)
  - Decision support information to assist in management decisions (mostly reactive to current operational performance measurements)
  - Trends and patterns based on past history (both recent and long-term past)
- **Dashboards are typically tied to the following methodologies or concepts**
  - Business Process Management (BPM)
  - Business Activity Monitoring (BAM)
  - Balanced Scorecard (BSC)





# Dashboard for Predictive Analytics

└ (Real-Time Look Ahead)

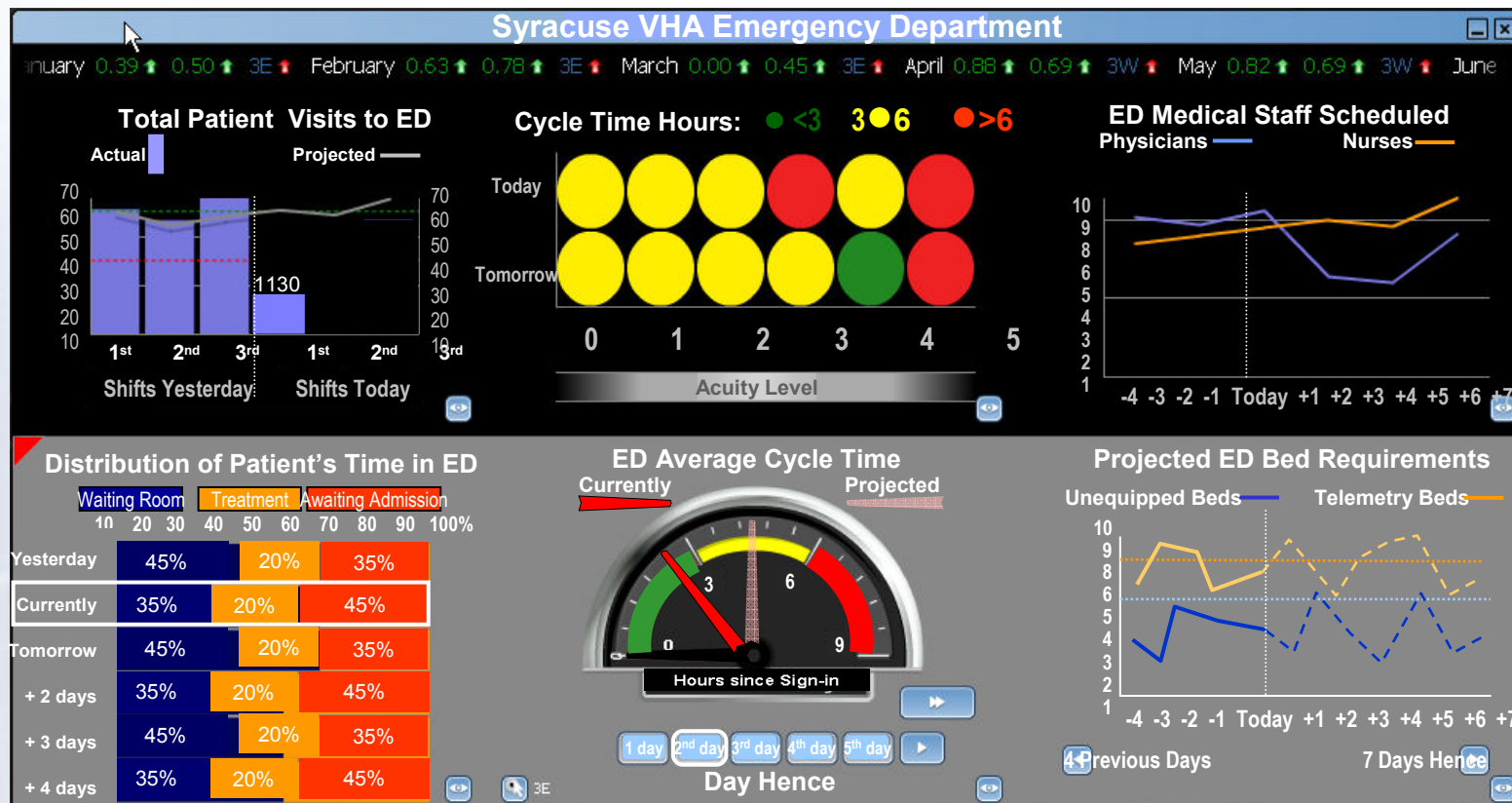

## Dashboards are most commonly implemented as part of:

- Business Intelligence/Decision Support solutions (e.g., Business Objects, Cognos, Hyperion, or Information Builders)
- Enterprise Application Integration solutions (e.g., SeeBeyond, Vitria, or Intersystems)
- Enterprise Applications (e.g., ERP or custom integrated solutions)



# Role of Process Simulation in Business Intelligence Dashboards

## Simulation extends the capability of traditional BI performance monitoring solutions and dashboards

- Provides a means of continuous business process performance monitoring and management by using the same business models to improve and predict in an operational environment
  - Tie measurements to simulated business process models
- Ad hoc simulations triggered by alarms such as thresholds or degradation in key measurements
  - Peek into the future using a validated process to gain lead time to affect business performance
  - Use both historical data and context-sensitive process models to predict most likely outcomes
- Examine, automatically, the possible performance outcomes for several validated process alternatives used/chosen by management
  - Basically person-in-loop decision support enhanced by automatic simulations of various alternatives
  - Extends the usefulness of business process models into a service oriented architecture for simulation-on-demand



# Sophistication Level 3 Case Study – Census Management

How many sorters to process 11  
million forms per day?

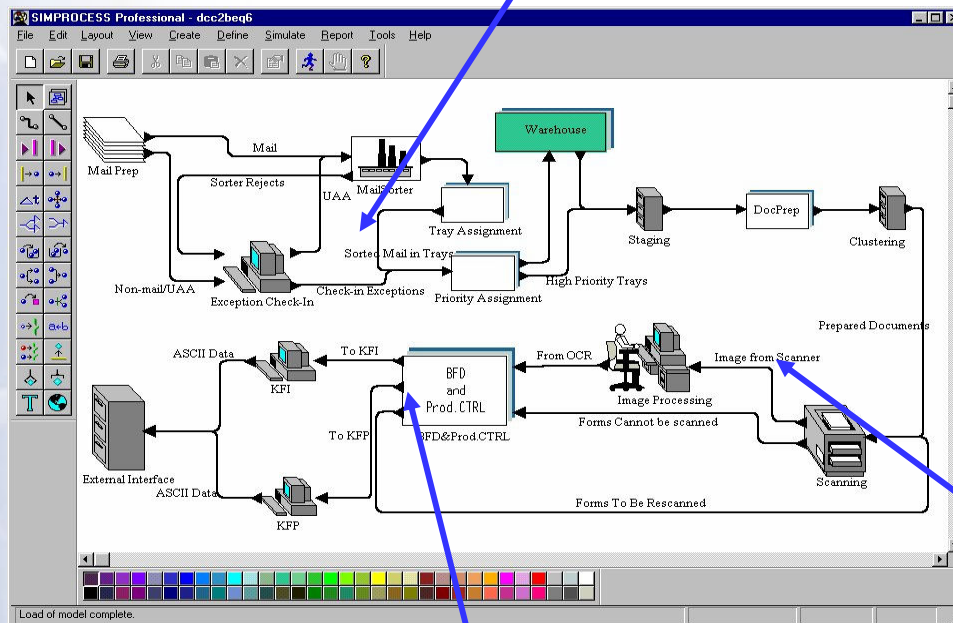

- Capacity of system elements
- Equipment and human resources required for each process
- Processing and data support required
- Process architecture of prototype facility
- Cost of adequate resources
- Balancing of network flow

Will our network  
handle the data flows?

How many scanners do we need to  
process 160 million forms in 100 days?



# Types of Forms

- **Mailed**
  - Be Counted Forms (BC)
  - Short forms with name capture (shortmailsur)
  - Short forms without name capture (shortmailnosur)
  - Long forms with name capture (longmailsur)
  - Long forms without name capture (longmailnosur)
  - Undeliverable as addressed long form (UAAL)
  - Undeliverable as addressed short form (UAAS)
  
- **Enumerator returns**
  - Group Quarter short forms (GQS)
  - Group Quarter long forms (GQL)
  - Short form enumerator returns (shortenum)
  - Long form enumerator returns (longenum)







# How it All Fits Together

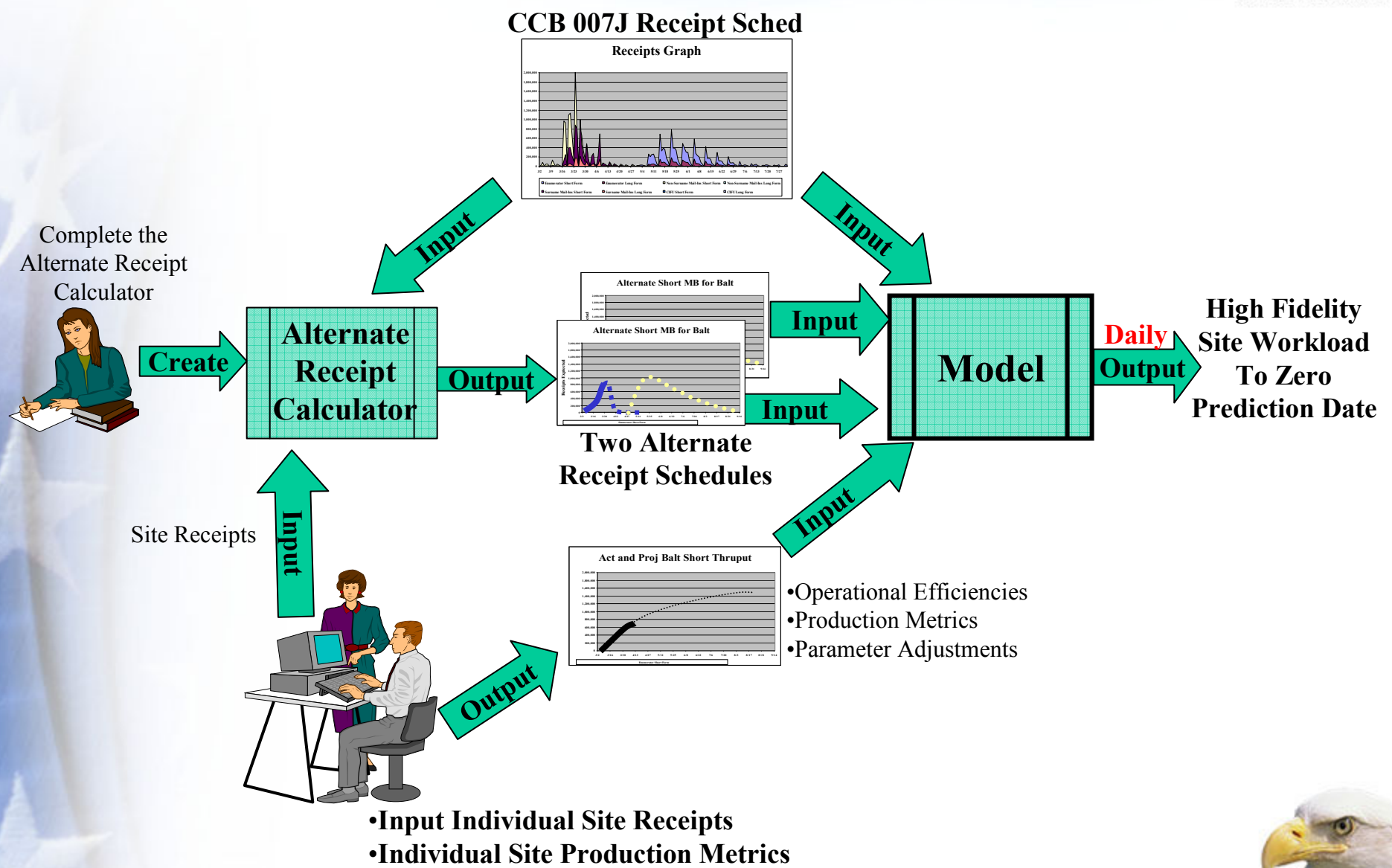



# Census Main Screen

## Resource Utilization and Completion Dates



Forecasted Workload



Resource Utilization and Completion Dates

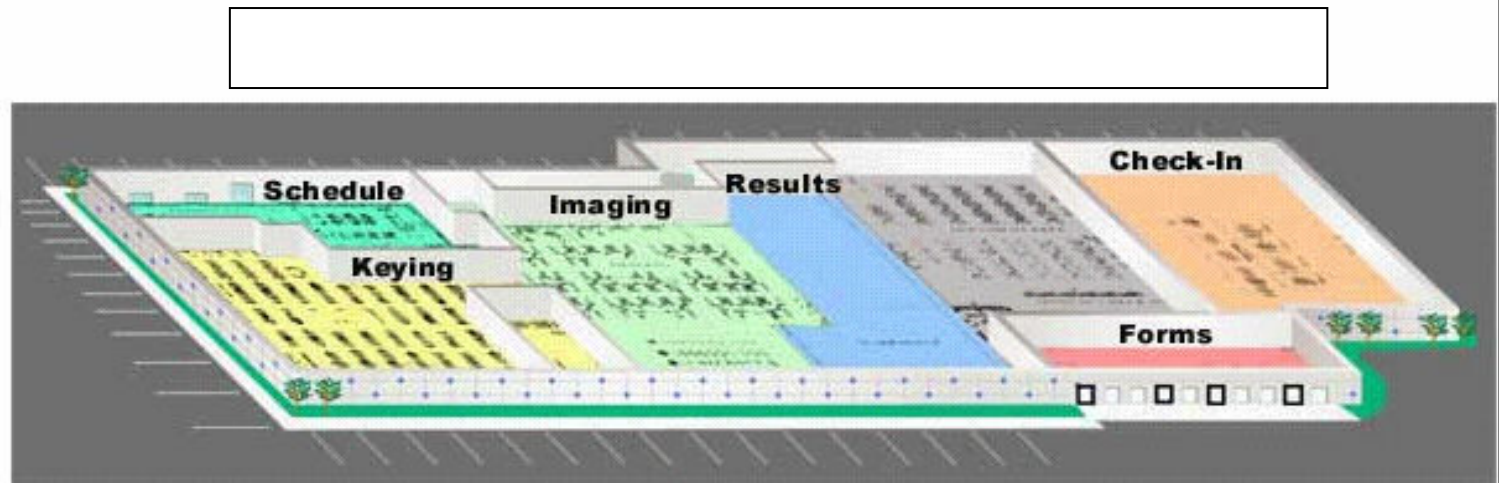

Administration



Links



Feedback

Receipt Schedule:

CCB007J Traditional Receipt Schedule  
CCB007J Traditional Receipt Schedule  
Adjusted receipts arrival (placeholder)  
Adjusted Mailback receipt volume (placeholder)

Site:

Baltimore, MD  
Baltimore, MD  
Jeffersonville, IN  
Phoenix, AZ  
Pomona, CA

# Backlog at a Single Processing Center

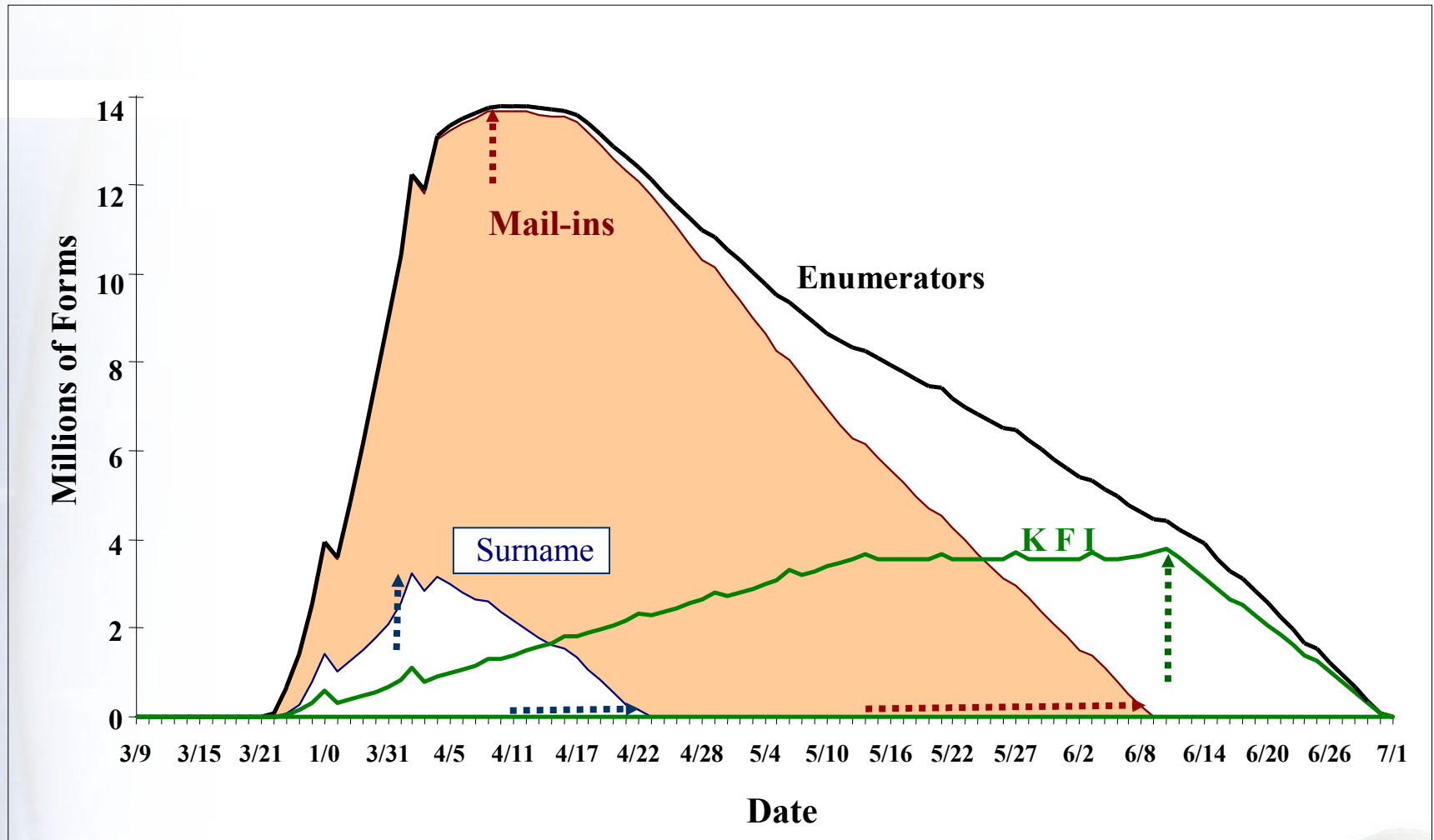

# Scanner-Keying Backlog Graph

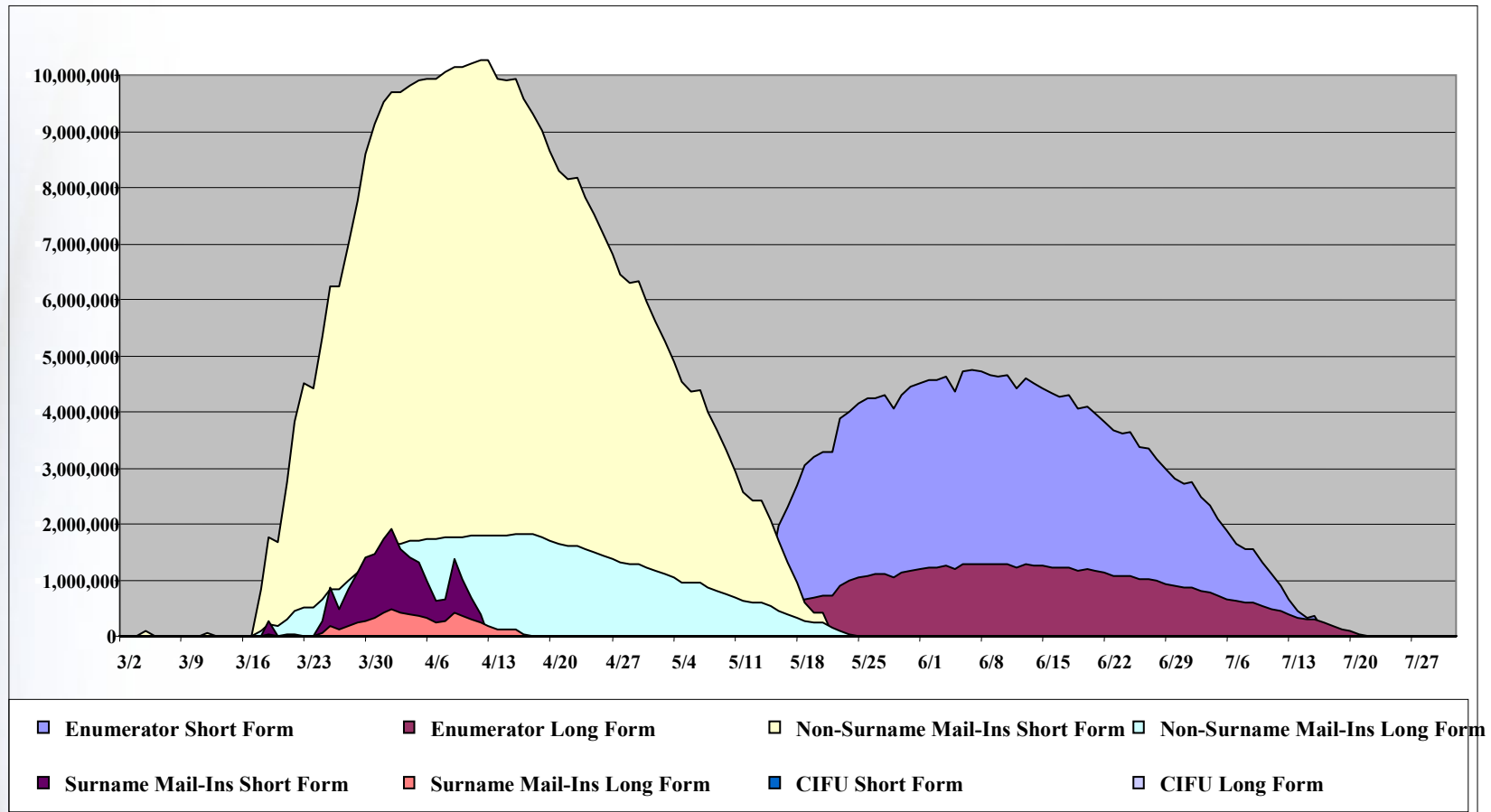

## Evolution of the Role for Process Simulation

- **Sophistication Level 1** is a traditional stand-alone desktop application where an expert modeler constructs the model, executes simulations and then reports analysis results to the Customer (Decision Maker). Sophistication Level 1 simulations are relatively simple applications and require extensive modeler involvement to execute analyses.
- **Sophistication Level 2** is a server-based, context-specific application (often a web-based browser application) with an imbedded simulation that is used by Subject Matter Analysts to define experiments, launch simulations and perform analyses. Sophistication Level 2 simulations are moderately complex applications and require minimal modeler involvement to define experiments and execute analyses.
- **Sophistication Level 3** is a server-based, dashboard application (also with an imbedded simulation) that is used by Decision Makers to monitor projected process performance and to explore the impact of perturbations to a limited set of process parameters. Sophistication Level 3 simulations are very complex applications and should require no modeler involvement.



# Empowerment through Levels of Sophistication



## Sophistication Level 1

Desktop simulation models used by simulation modelers to support operational improvement analysis.

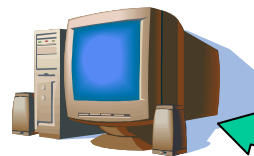

## Sophistication Level 2

Web-server hosted operational analysis tools available to a large community of functional analysts and decision makers.

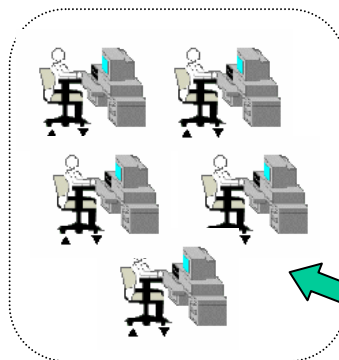

## Sophistication Level 3

Automated Predictive Analytics for proactive operations management by line managers and administrators.

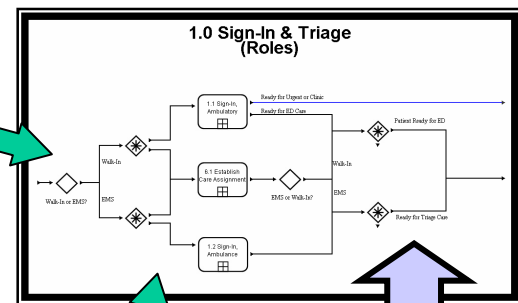

Data from Business Activity Monitoring  
*(historical & real-time)*

*(triggered by live data and events)*

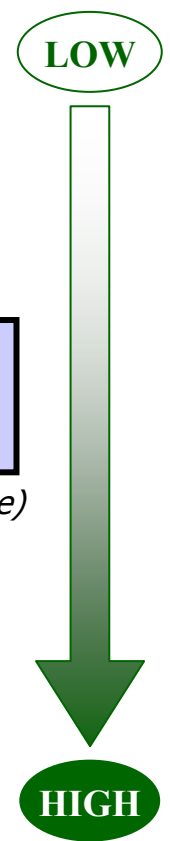

**Complexity of Solution**

**Training Required**  
**User Involvement w/ Model Details**



# Simplify the Problem

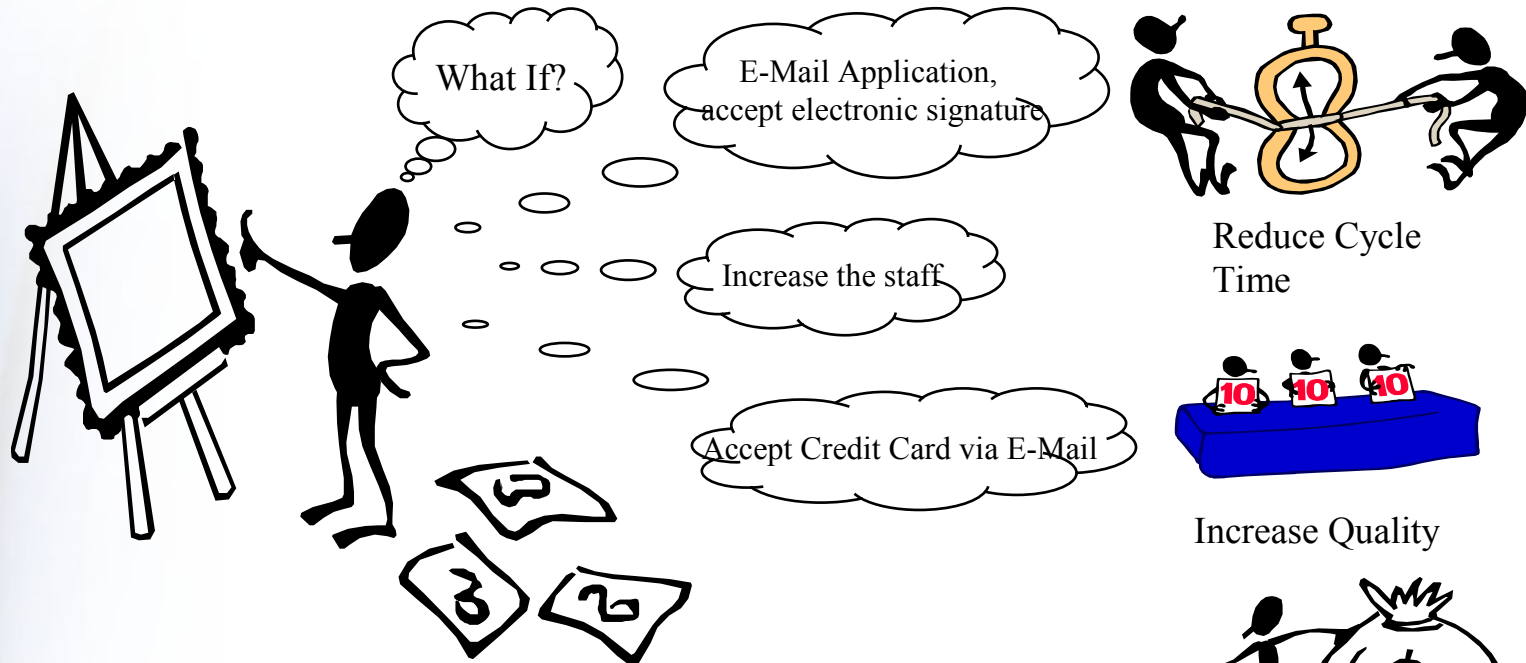

Design Experiments based on Process Owner Improvement Ideas:

1. Staffing ...
2. Workflow ...
3. Systems ...
4. Business Rules ...





# Contact Information

[www.caci.com](http://www.caci.com)



- This presentation can be downloaded at
- [www.simprocess.com](http://www.simprocess.com)

Wesley “Kit” Jones  
Business Process Expert  
(703) 679-4115  
[kitjones@caci.com](mailto:kitjones@caci.com)

Christine McCarty  
Quality Assurance Engineer  
(703) 460-1951  
[cmccarty@caci.com](mailto:cmccarty@caci.com)

